

■ INTRODUCTION

The CE1615 is a current limited P-channel MOSFET power switch designed for high-side load switching applications. This switch operates with inputs ranging from 2.5V to 5.5V, making it ideal for both 3V and 5V systems. An integrated current-limiting circuit protects the input supply against large currents which may cause the supply to fall out of regulation. The CE1615 is also protected from thermal overload which limits power dissipation and junction temperatures. It can be used to control loads that require up to 1.5A. Current limit threshold is programmed with a resistor from SET to ground.

■ FEATURES

- Low quiescent current: 9µA(Typ.)
- Shutdown Current: <1µA
- Programmable Over-Current Threshold
- Fast Transient Response: 400ns Response to Short Circuit
- Input Voltage: 2.5V~5.5V
- Low $R_{DS(ON)}$ Internal Switches: 145mΩ
- Only 2.5V Needed for ON/OFF Control
- Under-Voltage Lockout
- Thermal Fault Protection
- 4KV ESD Rating
- Temperature Range: -40°C to +85°C
- Package: SOT-23-5

■ APPLICATIONS

- Hot-Plug Power Supplies
- Battery-Charger Circuits
- Motherboard USB Power Switch
- Notebook Computers
- Personal Communication Devices
- USB Device Power Switch

■ BLOCK DIAGRA

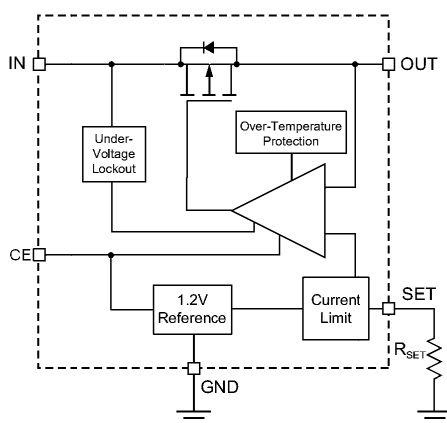

■ ORDER INFORMATION

CE1615①②③

DESIGNATOR	SYMBOL	DESCRIPTION
①	A	$I_{LIM} = 1.6A$ @ $R_{SET} = 6.8k\Omega$
②	H	CE High Active
	L	CE Low Active
③	M	Package: SOT-23-5

■ PIN CONFIGURATION

SOT-23-5
(Top View)

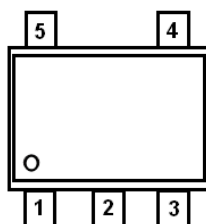

PIN NUMBER	SYMBOL	FUNCTION
1	OUT	P-channel MOSFET drain. Connect a 0.47 μ F capacitor from OUT to GND.
2	GND	Ground Pin
3	SET	Current limit set input. A resistor from SET to ground sets the current limit for the switch.
4	CE	Chip Enable input. Two versions are available, active-high and active-low. See Ordering Information for details.
5	IN	P-channel MOSFET source. Connect a 1 μ F capacitor from IN to GND.

■ ABSOLUTE MAXIMUM RATINGS

(Unless otherwise specified, Ta=25°C)

PARAMETER	SYMBOL	RATINGS	UNITS
Input Voltage	V_{IN}	-0.3~ 6	V
CE, SET, OUT Voltage	V_{CE}, V_{SET}, V_{OUT}	-0.3~ $V_{IN}+0.3$	V
Maximum Continuous Switch Current	I_{MAX}	2	A
Power Dissipation	SOT-23-5	Pd	400
Operating Temperature Range	T_{opr}	-40~+85	°C
Junction Temperature	T_j	125	°C
Storage Temperature	T_{stg}	-40~+125	°C
ESD Rating2 - HBM 4000 V	V_{ESD}	4000	V
Soldering Temperature & Time	T_{solder}	260°C, 10s	

■ ELECTRICAL CHARACTERISTICS

CE1615

(V_{IN}=5.0V, T_a=25°C, unless otherwise specified)

PARAMETER	SYMBOL	CONDITIONS	MIN	TYP	MAX	UNITS
Operation Voltage	V _{IN}		2.5		5.5	V
Quiescent Current	I _Q	V _{IN} =5V, CE=Active, I _{OUT} =0		9	25	μA
Off Supply Current	I _{Q(OFF)}	CE=Inactive, V _{IN} =5.5V			1	μA
Off Switch Current	I _{SD(OFF)}	CE=Inactive, V _{IN} =5.5V, V _{OUT} =0V		0.01	1	μA
Under-Voltage Lockout	V _{UVLO}	Rising Edge, 1% Hysteresis		1.8	2.4	V
On Resistance	R _{DS(ON)}	V _{IN} =5.0V		145	180	mΩ
		V _{IN} =4.5V		150		
		V _{IN} =3.0V		190	230	
Current Limit	I _{LIM}	R _{SET} =6.8kΩ	1.2	1.6	2.0	A
Minimum Current Limit	I _{LIM(MIN)}			150		mA
CE Input Low Voltage	V _{CE(L)}	V _{IN} =2.5V~5.5V			0.8	V
CE Input High Voltage	V _{CE(H)}	V _{IN} =2.5V~3.6V	2.0			V
		V _{IN} =4.5V~5.5V	2.4			
CE Input Leakage	I _{LEAK(CE)}	V _{CE} =5.5V		0.01	1	μA
Current Limit Response Time	T _{RESP}	V _{IN} =5.0V		0.4		μs
Turn-Off Time	T _{OFF}	V _{IN} =5.0V, R _L =10Ω		4	12	μs
Turn-On Time	T _{ON}	V _{IN} =5.0V, R _L =10Ω		12	200	μs
Over-Temperature Threshold	T _{SD}	V _{IN} =5.0V	T _J Increasing		125	°C
			T _J Decreasing		115	

■ TYPICAL APPLICATION

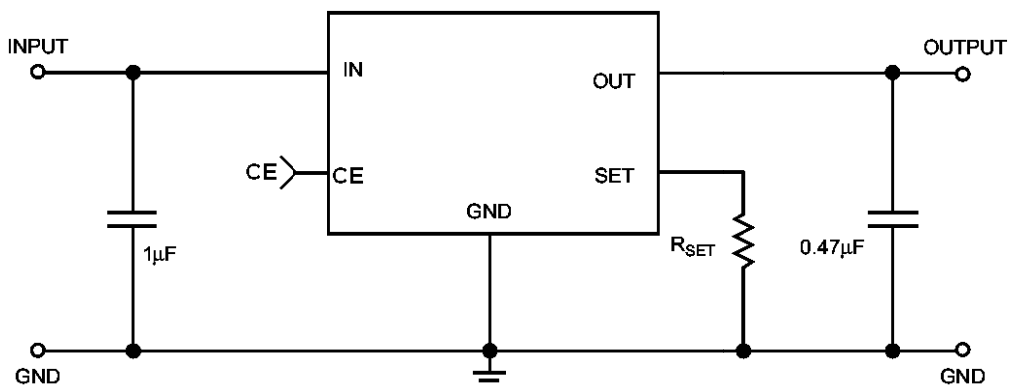

■ TYPICAL PERFORMANCE CHARACTERISTICS

(Unless otherwise noted, $V_{IN}=5V$, $T_A=25^\circ C$)

Quiescent Current vs. Temperature

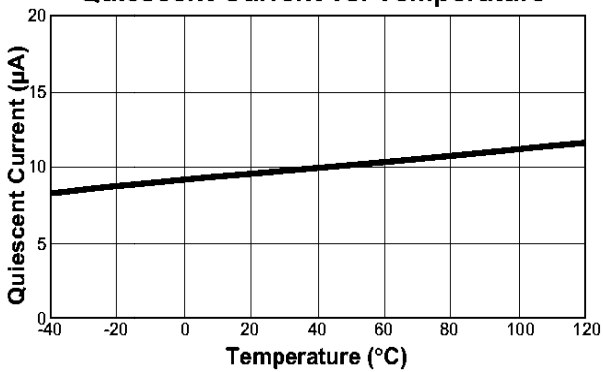

Quiescent Current vs. Input Voltage

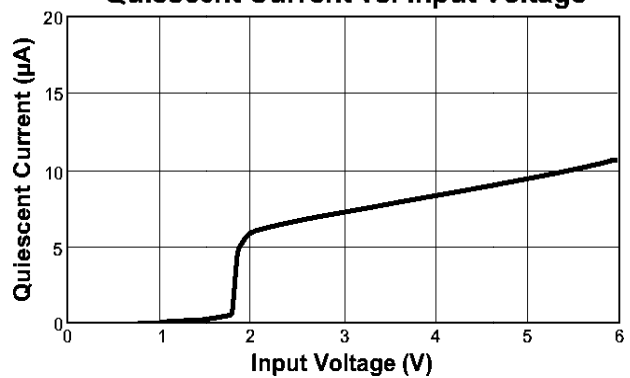

Output Current vs. Output Voltage

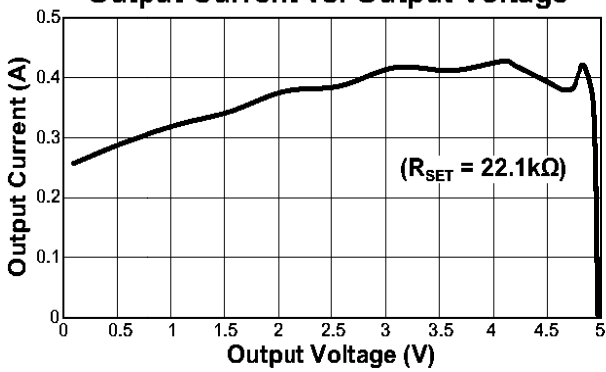

$R_{DS(ON)}$ vs. Temperature

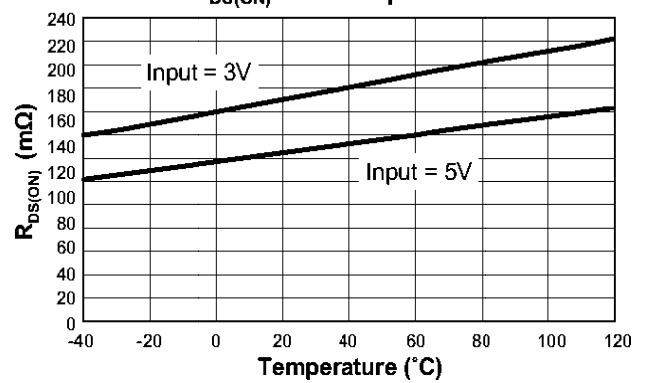

Off-Supply Current vs. Temperature

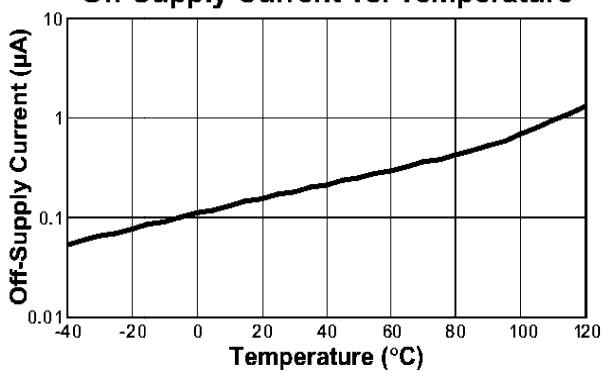

Off-Switch Current vs. Temperature

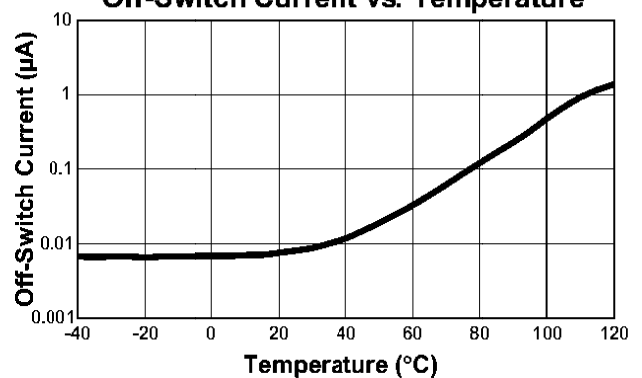

■ TYPICAL PERFORMANCE CHARACTERISTICS

(Unless otherwise noted, $V_{IN}=5V$, $T_A=25^\circ C$)

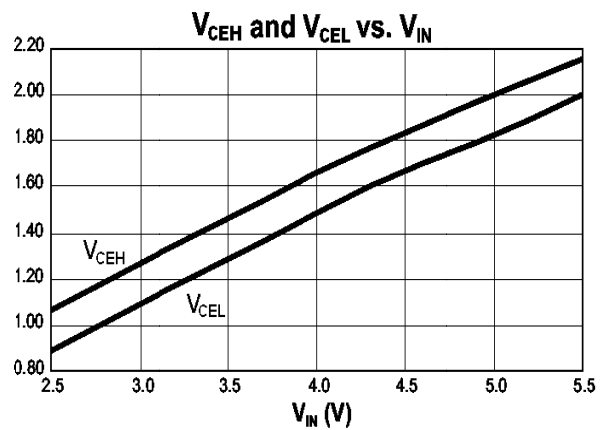
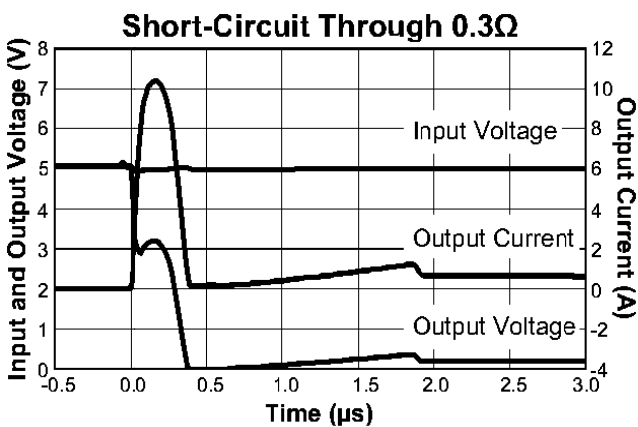
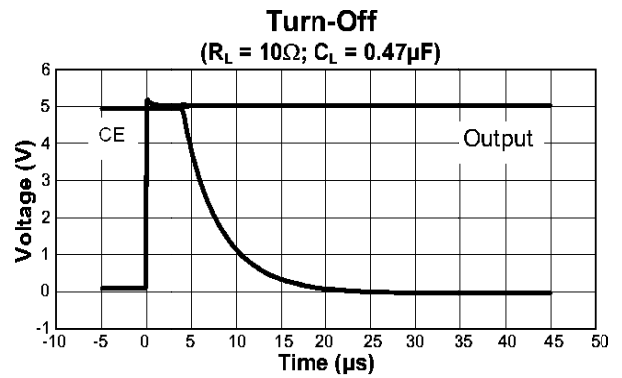
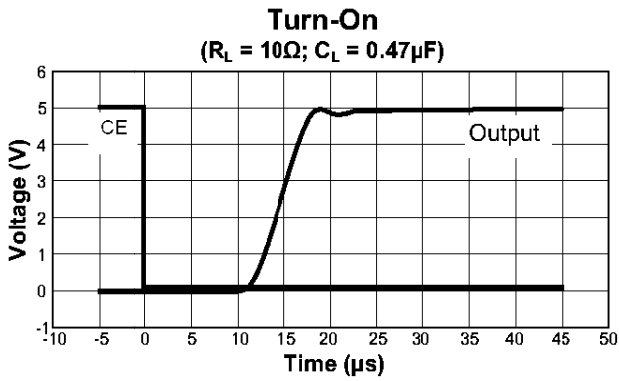
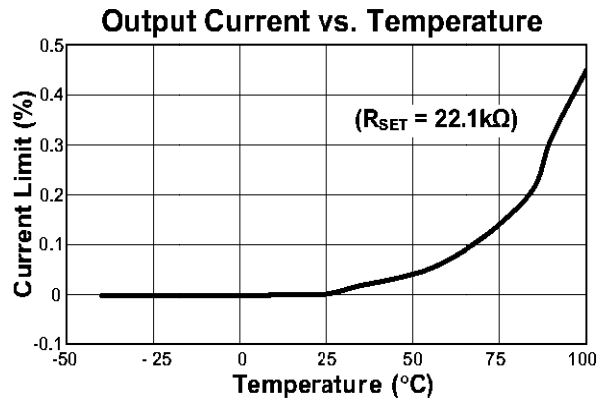
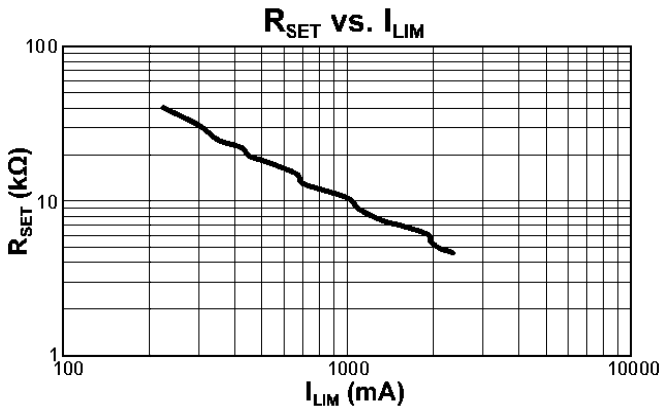

■ OPERATION

Setting Current Limit

In most applications, the variation in I_{LIM} must be taken into account when determining R_{SET} . The I_{LIM} variation is due to processing variations from part to part, as well as variations in the voltages at IN and OUT, plus the operating temperature. See charts “Current Limit vs. Temperature” and “Output Current vs. Output Voltage.” Together, these three factors add up to a $\pm 25\%$ tolerance (see I_{LIM} specification in Electrical Characteristics section). Figure 1 illustrates a cold device with a statistically higher current limit and a hot device with a statistically lower current limit, both with R_{SET} equal to $8.87k\Omega$. While the chart, “ R_{SET} vs. I_{LIM} ” indicates an I_{LIM} of $1.1A$ with an R_{SET} of $8.87k\Omega$, this figure shows that the actual current limit will be at least $0.825A$ and no greater than $1.375A$.

To determine R_{SET} , start with the maximum current drawn by the load and multiply it by 1.33 (typical $I_{LIM} = \text{minimum } I_{LIM} / 0.75$). This is the typical current limit value. Next, refer to “ R_{SET} vs. I_{LIM} ” and find the R_{SET} that corresponds to the typical current limit value. Choose the largest resistor available that is less than or equal to it. The maximum current is derived by multiplying the typical current for the chosen R_{SET} in the chart by 1.25 . A few standard resistor values are listed in Table 1.

R_{SET} (k Ω)	Current Limit Typ.(mA)	Device Will Not Current Limit Below (mA)	Device Always Current Limits Below (mA)
40.2	225	169	281
30.9	300	225	375
24.9	350	263	438
22.1	425	319	531
19.6	450	338	563
17.8	525	394	656
16.2	600	450	750
14.7	675	506	844
13.0	700	525	875
10.5	1000	750	1250
8.87	1100	825	1375
7.50	1325	994	1656
6.81	1600	1200	2000
6.04	1925	1444	2406
5.49	1950	1463	2438
4.99	2100	1575	2625
4.64	2350	1763	2938

Table 1: Current Limit R_{SET} Values

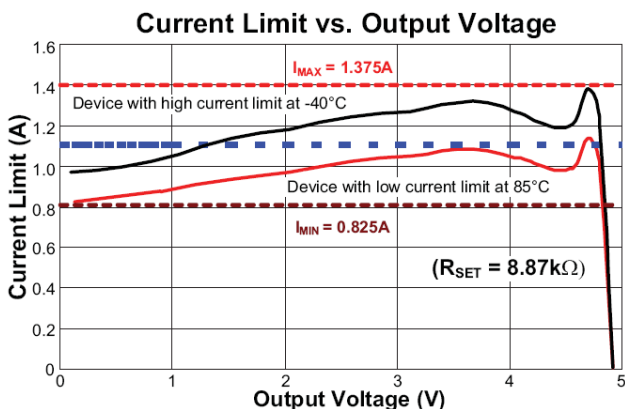

Fig.1 Current Limit Using $8.87k\Omega$

Example: A USB port requires $0.5A$. $0.5A$ multiplied by 1.33 is $0.665A$. From the chart named “ R_{SET} vs. I_{LIM} ,” R_{SET} should be less than $18k\Omega$. $17.8k\Omega$ is a standard value that is a little less than $18k\Omega$ but very close. The chart reads approximately $0.525A$ as a typical I_{LIM} value for $17.8k\Omega$. Multiplying $0.525A$ by 0.75 and 1.25 shows that the CE1615 will limit the load current to greater than $0.394A$ but less than $0.656A$.

Operation in Current Limit

When a heavy load is applied to the output of the CE1615, the load current is limited to the value of I_{LIM} determined by R_{SET} . Since the load is demanding more current than I_{LIM} , the voltage at the output drops. This causes the CE1615 to dissipate a larger than normal quantity of power, and its die temperature to increase. When the die temperature exceeds an over-temperature limit, the CE1615 will shut down until it has cooled sufficiently, at which point it will startup again. The CE1615 will continue to cycle on and off until the load is removed, power is removed, or until a logic high level is applied to ON.

Enable Input

In many systems, power planes are controlled by integrated circuits which run at lower voltages than the power plane itself. The enable input ON of the CE1615 has low and high threshold voltages that accommodate this condition. The threshold voltages are compatible with 5V TTL and 2.5V to 5V CMOS.

Reverse Voltage

The CE1615 is designed to control current flowing from IN to OUT. If a voltage is applied to OUT which is greater than the voltage on IN, large currents may flow. This could cause damage to the CE1615.

■ PACKAGING INFORMATION

● SOT23-5 Package Outline Dimensions

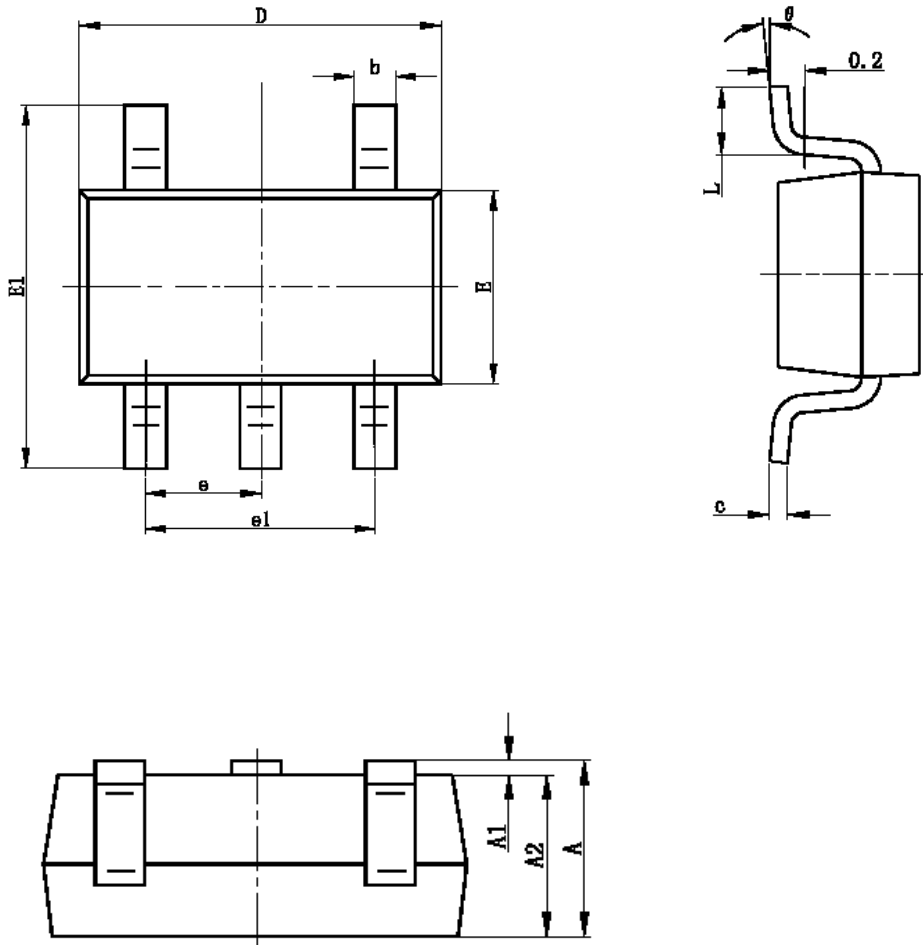

Symbol	Dimensions In Millimeters		Dimensions In Inches	
	Min	Max	Min	Max
A	1.050	1.250	0.041	0.049
A1	0.000	0.100	0.000	0.004
A2	1.050	1.150	0.041	0.045
b	0.300	0.500	0.012	0.020
c	0.100	0.200	0.004	0.008
D	2.820	3.020	0.111	0.119
E	1.500	1.700	0.059	0.067
E1	2.650	2.950	0.104	0.116
e	0.950(BSC)		0.037(BSC)	
e1	1.800	2.000	0.071	0.079
L	0.300	0.600	0.012	0.024
θ	0°	8°	0°	8°

© Nanjing Chipower Electronics Inc.

Chipower cannot assume responsibility for use of any circuitry other than circuitry entirely embodied in a Chipower product. No circuit patent license, copyrights or other intellectual property rights are implied. Chipower reserves the right to make changes to their products or specifications without notice. Customers are advised to obtain the latest version of relevant information to verify, before placing orders, that information being relied on is current and complete.