

■ **INTRODUCTION:**

The CE3102 is a complete constant-current constant-voltage linear charger for small current Li-Ion button battery. It's SOT package and low external component count make the CE3102 especially well-suit for portable applications. Furthermore, the CE3102 is specifically designed to work within USB Power specifications.

No external sense resistor is needed and no blocking diode is required due to internal MOSFET architecture. The charge voltage is fixed at 4.2V and the charge current can be programmed externally with a single resistor. The CE3102 automatically terminates the charge cycle when the charge current drops to 1/10th the programmed value after the final float voltage is reached. The CE3102 automatically re-starts the charge if the battery voltage falls below an internal threshold.

■ **FEATURES:**

- Programmable Charge Current Up to 120mA
- No External MOSFET, Sense Resistor or Blocking Diode Required
- Charges Single Cell Li-Ion Button Batteries Directly from USB Port
- Preset 4.2V Charge Voltage with $\pm 1.2\%$ Accuracy
- Constant-Current Constant-Voltage
- Charge Status Output Pin
- 30 μ A Shutdown Current
- 70 μ A Standby Current
- Complete Linear Charger in SOT23-5 Package and DFN1.8 \times 2.0-6 for Single Cell Lithium-Ion Button Battery
- C/10 Charge Termination
- Soft-Start Limits Inrush Current
- Automatic Recharge

■ **APPLICATIONS:**

- PDAs
- Toys
- Lighting
- 3D Glass

■ **PIN CONFIGURATION:**

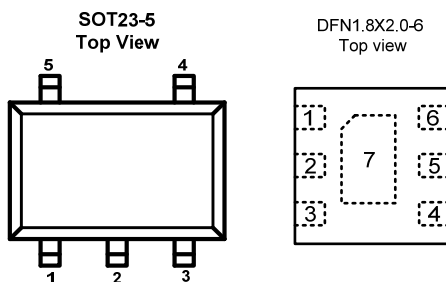

■ **ORDER INFORMATION:**

CE3102①②

DESIGNATOR	SYMBOL	DESCRIPTION
①	A	Standard
②	M	Package: SOT23-5
	FB6	Package: DFN1.8 \times 2.0-6

Tabel1. SOT23-5 Pin Description

PIN NUMBER	PIN NAME	FUNCTION
1	CHG	Open-Drain Charges Status Output
2	GND	Ground
3	BAT	Charge Current Output. The positive side of battery
4	VCC	Input supply Voltage
5	PROG	Charge Current Program, Charge Current Monitor and Shutdown Pin

Tabel2. DFN1.8×2.0-6 Pin Description

PIN NUMBER	PIN NAME	FUNCTION
1	BAT	Charge Current Output. The positive side of battery
2	GND	Ground
3	CHG	Open-Drain Charges Status Output
4	PROG	Charge Current Program, Charge Current Monitor and Shutdown Pin
5	NC	No Connected
6	VCC	Input supply Voltage

■ BLOCK DIAGRAM

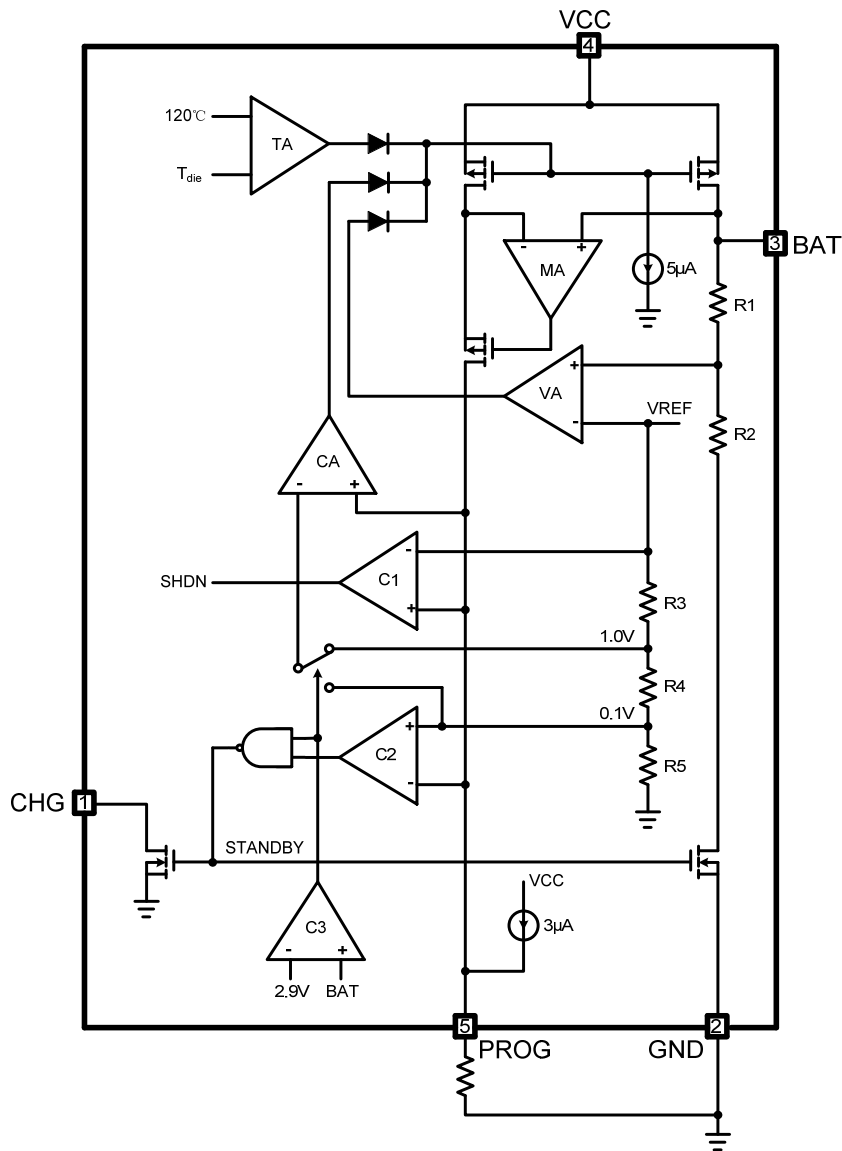

■ ABSOLUTE MAXIMUM RATINGS

(Unless otherwise specified, Ta=25°C)

PARAMETER	SYMBOL	RATINGS	UNITS
Input Voltage	V_{IN}	$V_{SS}-0.3 \sim V_{SS}+8$	V
Prog Pin Voltage	V_{PROG}	$V_{SS}-0.3 \sim V_{IN}+0.3$	V
CHG,BAT Pin Voltage	V_{BAT}	$V_{SS}-0.3 \sim V_{SS}+8$	V
BAT Pin Current	I_{BAT}	120	mA
Power Dissipation	SOT23-5	P_d	300
	DFN1.8×2.0-6	P_d	2000
Operating Temperature	T_{opr}	-40~+85	°C
Junction Temperature	T_j	125	°C
Storage Temperature	T_{stg}	-40~+125	°C
Soldering Temperature & Time	T_{solder}	260°C, 10s	

■ ELECTRICAL CHARACTERISTICS

CE3102 Series ($V_{IN}=5.0V$, $T_a=25^{\circ}C$, Test Circuit Figure1, unless otherwise specified)

PARAMETER	SYMBOL	CONDITIONS	MIN	TYP	MAX	UNITS
Input Supply Voltage	V_{CC}		4.25	5.00	6.50	V
Input Supply Current	I_{CC}	Charge Mode, $R_{PROG}=10k$		200	500	μA
		Standby Mode(Charge Terminated)		70	100	μA
		Shutdown Mode: R_{PROG} Not Connected, $V_{CC}<V_{BAT}$, or $V_{CC}<V_{UV}$		30	50	μA
Regulated Output (Float) Voltage	V_{FLOAT}	$0^{\circ}C \leq T_A \leq 85^{\circ}C$, $I_{BAT} = 2mA$, $R_{PROG}=10k$	4.150	4.2	4.250	V
BAT Pin Current	I_{BAT}	$R_{PROG} = 10k$, Current Mode	9	12	15	mA
		$R_{PROG} = 2k$, Current Mode	45	60	75	mA
		Standby Mode, $V_{BAT} = 4.2V$	0	-2.5	-6.0	μA
		Shutdown Mode (R_{PROG} Not Connected)		± 1	± 2	μA
		Sleep Mode, $V_{CC} = 0V$		± 1	± 2	μA
Trickle Charge Current	I_{TRIKL}	$V_{BAT} < 2.9V$, $R_{PROG} = 2k$	2.2	5.5	8	mA
Trickle Charge Threshold	V_{TRIKL}	$R_{PROG} = 10k$, V_{BAT} Rising	2.8	2.9	3.0	V
Trickle Charge Hysteresis	V_{TRHYS}	$R_{PROG} = 10k$		80		mV
VCC Under voltage Lockout Threshold	V_{UV}	V_{CC} from Low to High	3.7	3.8	3.9	V
VCC Under voltage Lockout Hysteresis	V_{UVHYS}			100		mV
Manual Shutdown Threshold	V_{MSD}	P_{ROG} Pin Rising		1.21		V
		P_{ROG} Pin Falling		1.0		
$V_{CC} - V_{BAT}$ Lockout Threshold	A_{MSD}	V_{CC} from Low to High		100		mV
		V_{CC} from High to Low		30		
C/10 Termination Current Threshold	I_{TERM}	$R_{PROG} = 10k$		0.1		mA/mA
		$R_{PROG} = 2k$		0.1		mA/mA
PROG Pin Voltage	V_{PROG}	$R_{PROG} = 10k$, Current Mode		1.0		V
CHG Pin Weak Pull Down Current	I_{CHG}	$V_{CHG}=5.0V$	8	20	35	μA
CHG Pin Output Low Voltage	V_{CHG}	$I_{CHG}=5.0mA$		0.35	0.8	V
Recharge Battery Threshold	ΔV_{RECHG}	$V_{FLOAT} - V_{RECHRG}$		100		mV
Junction Temperature in Constant Temperature Mode	T_{LIM}			120		$^{\circ}C$

■ TYPICAL APPLICATION CIRCUITS

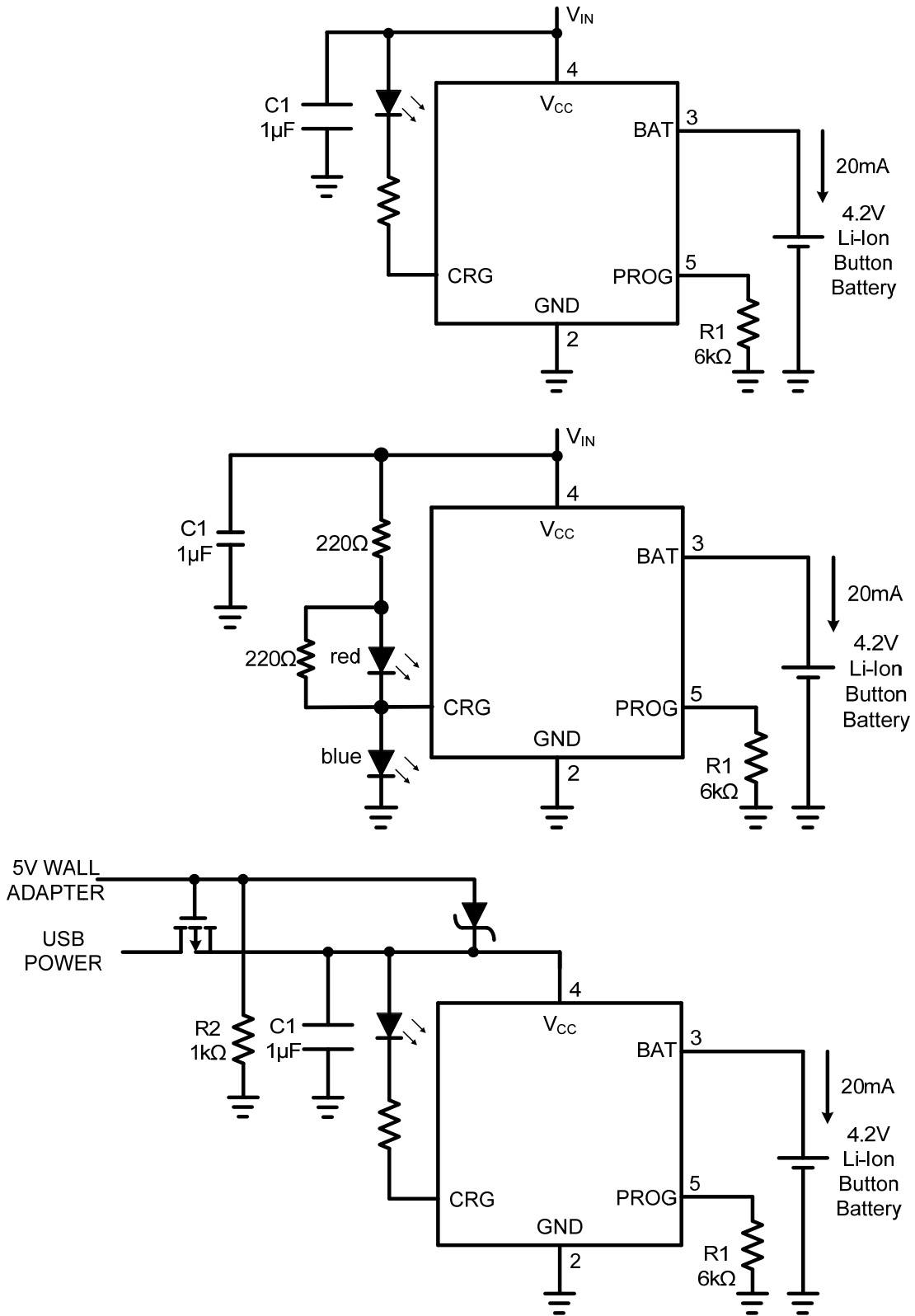

Figure1 Basic Application Circuit

■ OPERATION

The CE3102 is a standalone linear Li-ion button battery charger. It can deliver up to 120mA of charge current with a final float voltage accuracy of $\pm 1.2\%$.

No blocking diode or external current sense resistor is required. A charge cycle begins when the voltage at the VCC pin rises above the UVLO threshold level and a 1% program resistor is connected from the PROG pin to ground. If the BAT pin is less than 2.9V, the charger enters trickle charge mode. In this mode, the CE3102 supplies approximately 1/10 the programmed charge current to bring the battery voltage up to a safe level for full current charging. When the BAT pin voltage rises above 2.9V, the charger enters

constant-current mode, where the programmed charge current is supplied to the battery. When the BAT pin approaches the final float voltage (4.2V), the CE3102 enters constant-voltage mode and the charge current begins to decrease. When the charge current drops to 1/10 of the programmed value, the charge cycle ends.

After a charge cycle is complete and charging operation is terminated, the CE3102 keeps monitoring the BAT voltage. If the battery voltage drops below 4.05V, a recharge cycle will begin. To manually restart the charge cycle, the input voltage must be removed and reapplied, or the charger must be shut down and restarted by momentarily floating the PROG pin.

■ APPLICATION INFORMATION

PROGRAMMING CHARGE CURRENT

The charge current is programmed using a single resistor from the PROG pin to ground. The battery charge current is 120 times the current out of the PROG pin. The program resistor and the charge current are calculated using the following equations:

$$R_{\text{PROG}} = \frac{120V}{I_{\text{CHG}}} \quad I_{\text{PROG}} = \frac{120V}{R_{\text{PROG}}}$$

STABILITY CONSIDERATIONS

The constant-voltage mode feedback loop is stable without an output capacitor provided a battery is connected to the charger output. With no battery present, an output capacitor is recommended to reduce ripple voltage. When using high value, low ESR ceramic capacitors, it is recommended to add a $1\ \Omega$ resistor in series with the capacitor. No series resistor is needed if tantalum capacitors are used.

In constant-current mode, the PROG pin is in the feedback loop, not the battery. The

constant-current mode stability is affected by the impedance at the PROG pin. With no additional capacitance on the PROG pin, the charger is stable with program resistor values as high as 30k. However, additional capacitance on this node reduces the maximum allowed program resistor. The pole frequency at the PROG pin should be kept above 100kHz. Therefore, if the PROG pin is loaded with a capacitance, C_{PROG} , the following equation can be used to calculate the maximum resistance value for R_{PROG} :

$$R_{\text{PROG}} \leq \frac{1}{2\pi \times 10^5 \times C_{\text{PROG}}}$$

Average, rather than instantaneous, charge current may be of interest to the user. For example, if a switching power supply operating in low current mode is connected in parallel with the battery, the average current being pulled out of the BAT pin is typically of more interest than the instantaneous current pulses. In such a case, a

simple RC filter can be used on the PROG pin to measure the average battery current. A 10k resistor has been added between the PROG pin and the filter capacitor to ensure stability.

CHARGE STATUS INDICATOR

The charge status output has three different states: strong pull-down (~5mA), weak pull-down (~20 μ A) and high impedance. The strong pull-down state indicates that the CE3102 is in a charge cycle. Once the charge cycle has terminated, the pin state is determined by under voltage lockout conditions. A weak pull-down indicates that VCC meets the UVLO conditions and the CE3102 is ready to charge. High impedance indicates that the CE3102 is in under voltage lockout mode: either VCC is within 100mV of the BAT pin voltage or insufficient voltage is applied to the VCC pin. A microprocessor can be used to distinguish between these three states.

THERMAL LIMITING

An internal thermal feedback loop reduces the programmed charge current if the die temperature attempts to rise above a preset value of approximately 120°C. This feature protects the CE3102 from excessive temperature and allows the user to push the limits of the power handling capability of a given circuit board without risk of damaging the CE3102.

UNDER VOLTAGE LOCKOUT (UVLO)

An internal under voltage lockout circuit monitors the input voltage and keeps the charger in shutdown mode until VCC rises above the under voltage lockout threshold. The UVLO circuit has a built-in hysteresis of 100mV. Furthermore, to protect against reverse current in the power MOSFET, the UVLO circuit keeps the charger in shutdown mode if VCC falls to within 30mV of the battery voltage. If the UVLO comparator is tripped, the charger will not come out of shutdown mode until VCC rises 100mV above the battery voltage.

MANUAL SHUTDOWN

At any point in the charge cycle, the CE3102 can be put into shutdown mode by removing R_{PROG} thus floating the PROG pin. This reduces the battery drain current to less than 2 μ A and the supply current to less than 50 μ A. A new charge cycle can be initiated by reconnecting the program resistor.

In manual shutdown, the CHG pin is in a weak pull-down state as long as VCC is high enough to exceed the UVLO conditions. The CHG pin is in a high impedance state if the CE3102 is in under voltage lockout mode: either VCC is within 100mV of the BAT pin voltage or insufficient voltage is applied to the VCC pin.

■ PACKAGING INFORMATION

● SOT23-5 Package Outline Dimensions

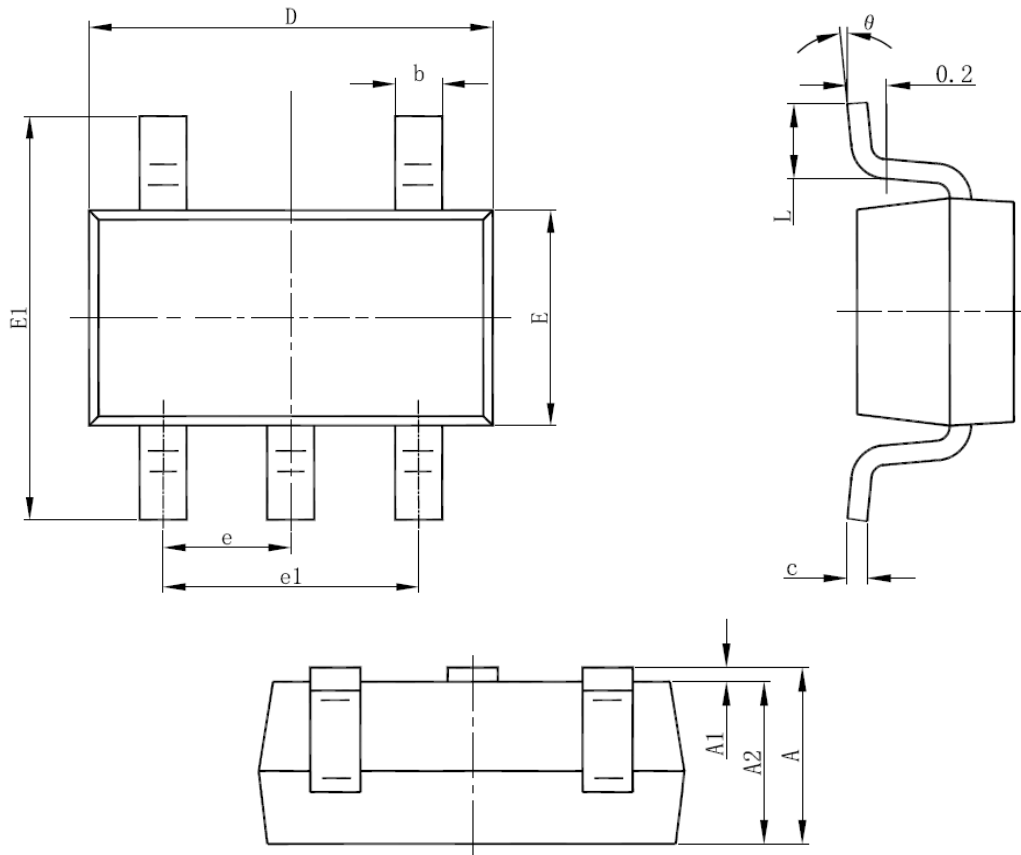

Symbol	Dimensions In Millimeters		Dimensions In Inches	
	Min	Max	Min	Max
A	1.050	1.250	0.041	0.049
A1	0.000	0.100	0.000	0.004
A2	1.050	1.150	0.041	0.045
b	0.300	0.500	0.012	0.020
c	0.100	0.200	0.004	0.008
D	2.820	3.020	0.111	0.119
E	1.500	1.700	0.059	0.067
E1	2.650	2.950	0.104	0.116
e	0.950(BSC)		0.037(BSC)	
e1	1.800	2.000	0.071	0.079
L	0.300	0.600	0.012	0.024
θ	0°	8°	0°	8°

● DFN1.8×2.0-6 Package Outline Dimensions

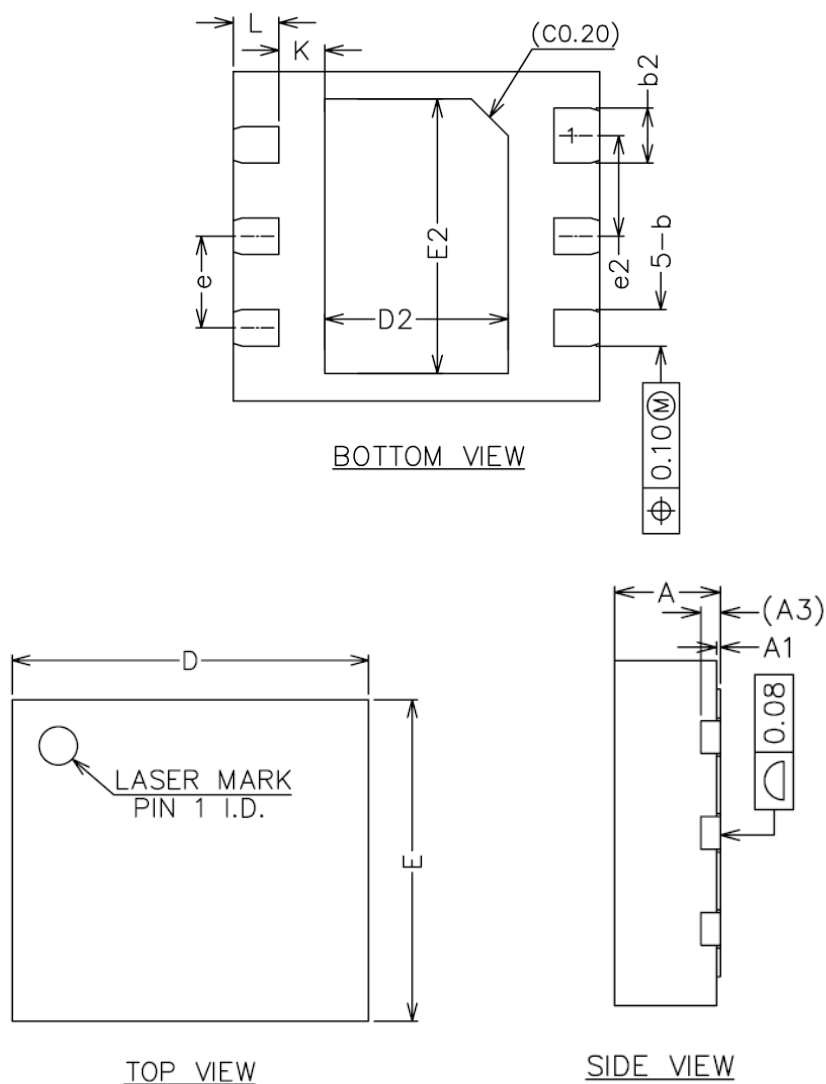

Symbol	Dimensions In Millimeters		
	Min.	Nom.	Max.
A	0.50	-	0.60
A1	0.00	0.02	0.05
A3	0.10REF		
b	0.15	0.20	0.25
b2	0.25	0.30	0.35
D	1.90	2.00	2.10
D2	0.90	1.00	1.10
E	1.70	1.80	1.90
E2	1.40	1.50	1.60
e	0.40	0.50	0.60
e2	0.45	0.55	0.65
K	0.15	-	-
L	0.20	0.25	0.30

© Nanjing Chipower Electronics Inc.

Chipower cannot assume responsibility for use of any circuitry other than circuitry entirely embodied in a Chipower product. No circuit patent license, copyrights or other intellectual property rights are implied. Chipower reserves the right to make changes to their products or specifications without notice. Customers are advised to obtain the latest version of relevant information to verify, before placing orders, that information being relied on is current and complete.