

■ **INTRODUCTION:**

The CE3150 is a complete constant-current constant-voltage linear charger for single cell Li-Ion batteries. It's SOT package and low external component count make the CE3150 especially well-suit for portable applications. Furthermore, the CE3150 is specifically designed to work within USB Power specifications.

No external sense resistor is needed and no blocking diode is required due to internal MOSFET architecture. Thermal feedback regulates the charge current to limit the die temperature. The charge voltage is fixed at 4.2V and the charge current can be programmed externally with a single resistor. The CE3150 automatically terminates the charge cycle when the charge current drops to 1/10th the programmed value after the final float voltage is reached. The CE3150 automatically re-starts the charge if the battery voltage falls below an internal threshold.

■ **APPLICATIONS:**

- Cellular Telephones, PDAs
- Charging Docks and Cradles

■ **PIN CONFIGURATION:**

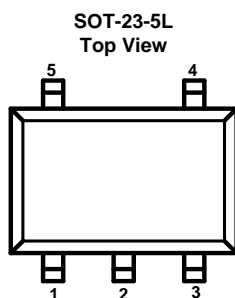

■ **FEATURES:**

- Programmable Charge Current Up to 800mA
- No External MOSFET, Sense Resistor or Blocking Diode Required
- Charges Single Cell Li-Ion Batteries Directly from USB Port
- Preset 4.2V Charge Voltage with $\pm 1.2\%$ Accuracy
- Constant-Current/Constant-Voltage Operation with Thermal Regulation to Maximize Charge Rate Without Risk of Overheating
- Charge Status Output Pin
- 30 μ A Shutdown Current
- 70 μ A Standby Current
- Complete Linear Charger in SOT23-5 Package for Single Cell Lithium-Ion Batteries
- C/10 Charge Termination
- Soft-Start Limits Inrush Current
- Automatic Recharge
- Portable MP3 Players
- Bluetooth Applications

■ **ORDER INFORMATION:**

CE3150①②

DESIGNATOR	SYMBOL	DESCRIPTION
①	A	Standard
②	M	Package: SOT-23-5L

Table1. Pin Description

PIN NUMBER	PIN NAME	FUNCTION
1	CHG	Open-Drain Charges Status Output
2	GND	Ground
3	BAT	Charge Current Output. The positive side of battery
4	VCC	Input supply Voltage
5	PROG	Charge Current Program, Charge Current Monitor and Shutdown Pin

■ BLOCK DIAGRAM

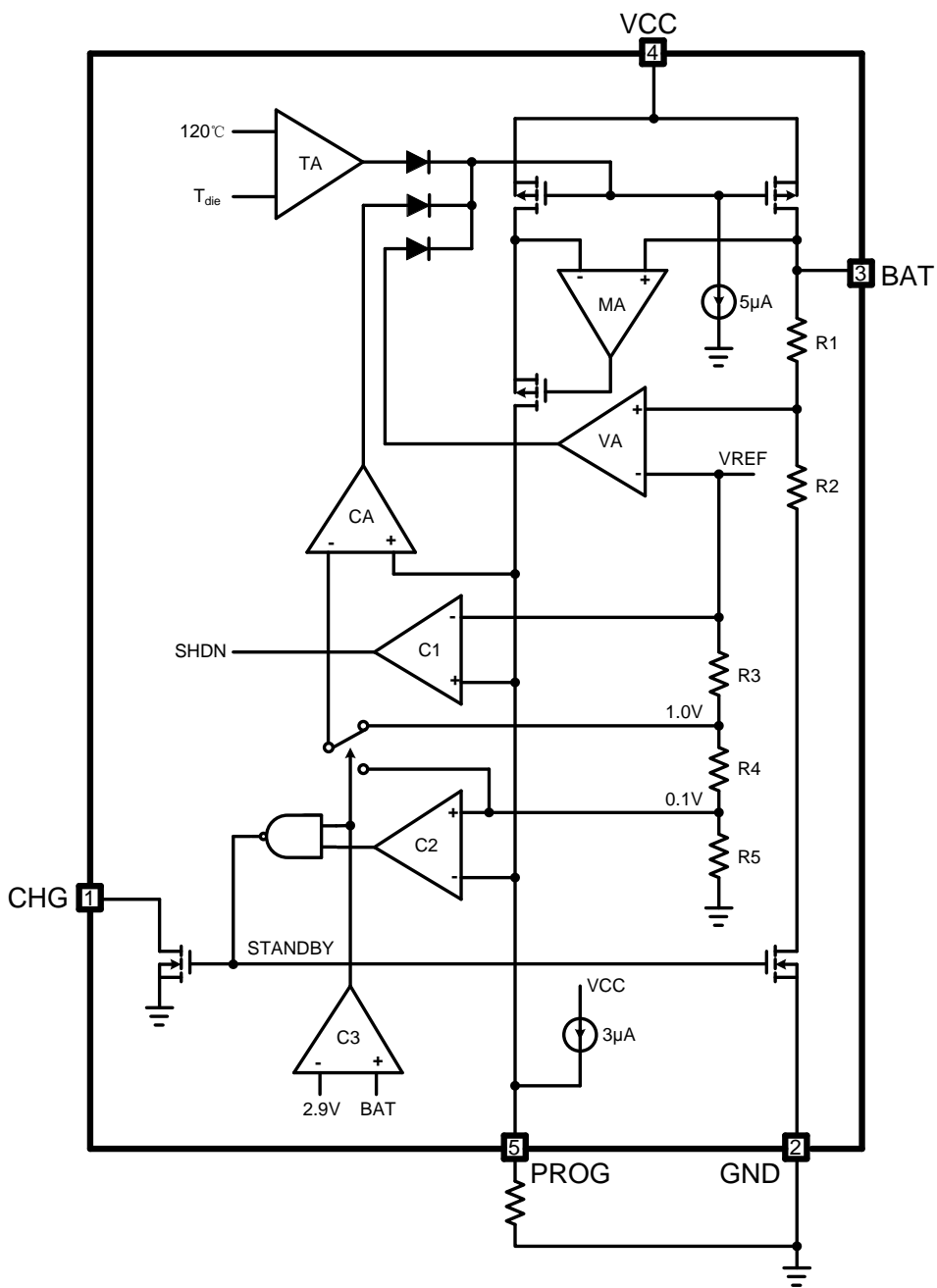

■ ABSOLUTE MAXIMUM RATINGS

(Unless otherwise specified, Ta=25°C)

PARAMETER	SYMBOL	RATINGS	UNITS	
Input Voltage	V_{IN}	$V_{SS}-0.3\sim V_{SS}+8$	V	
Prog Pin Voltage	V_{PROG}	$V_{SS}-0.3\sim V_{IN}+0.3$	V	
CHG,BAT Pin Voltage	V_{BAT}	$V_{SS}-0.3\sim V_{SS}+8$	V	
BAT Pin Current	I_{BAT}	800	mA	
Power Dissipation	SOT-23-5L	P_d	300	mW
Operating Temperature	T_{opr}	-40~+85	°C	
Junction Temperature	T_j	125	°C	
Storage Temperature	T_{stg}	-40~+125	°C	
Soldering Temperature & Time	T_{solder}	260°C, 10s		

■ ELECTRICAL CHARACTERISTICS

CE3150 Series ($V_{IN}=5.0V$, Ta=25°C, Test Circuit Figure1, unless otherwise specified)

PARAMETER	SYMBOL	CONDITIONS	MIN	TYP	MAX	UNITS
Input Supply Voltage	V_{CC}		4.25	5.00	6.50	V
Input Supply Current	I_{CC}	Charge Mode, $R_{PROG}=10k$		200	500	μA
		Standby Mode(Charge Terminated)		70	100	μA
		Shutdown Mode: R_{PROG} Not Connected, $V_{CC}<V_{BAT}$, or $V_{CC}<V_{UV}$		30	50	μA
Regulated Output (Float) Voltage	V_{FLOAT}	0°C ≤ TA ≤ 85°C, $I_{BAT}=20mA$, $R_{PROG}=10k$	4.150	4.2	4.250	V
BAT Pin Current	I_{BAT}	$R_{PROG} = 10k$, Current Mode	115	120	135	mA
		$R_{PROG} = 2k$, Current Mode	540	600	660	mA
		Standby Mode, $V_{BAT} = 4.2V$	0	-2.5	-6.0	μA
		Shutdown Mode (R_{PROG} Not Connected)		±1	±2	μA
		Sleep Mode, $V_{CC} = 0V$		±1	±2	μA
Trickle Charge Current	I_{TRIKL}	$V_{BAT} < 2.9V$, $R_{PROG} = 2k$	20	50	70	mA
Trickle Charge Threshold	V_{TRIKL}	$R_{PROG} = 10k$, V_{BAT} Rising	2.8	2.9	3.0	V
Trickle Charge Hysteresis	V_{TRHYS}	$R_{PROG} = 10k$		80		mV
VCC Under voltage Lockout Threshold	V_{UV}	V_{CC} from Low to High	3.7	3.8	3.9	V
VCC Under voltage Lockout Hysteresis	V_{UVHYS}			100		mV
Manual Shutdown Threshold	V_{MSD}	P_{ROG} Pin Rising		1.21		V

		P _{ROG} Pin Falling		1.0		
V _{CC} - V _{BAT} Lockout Threshold	A _{MSD}	V _{CC} from Low to High		100		mV
		V _{CC} from High to Low		30		
C/10 Termination Current Threshold	I _{TERM}	R _{PROG} = 10k		0.1		mA/mA
		R _{PROG} = 2k		0.1		mA/mA
PROG Pin Voltage	V _{PROG}	R _{PROG} = 10k, Current Mode		1.0		V
CHG Pin Weak Pull Down Current	I _{CHG}	V _{CHG} =5.0V	8	20	35	μA
CHG Pin Output Low Voltage	V _{CHG}	I _{CHG} =5.0mA		0.35	0.8	V
Recharge Battery Threshold	ΔV _{RECHG}	V _{FLOAT} - V _{RECHRG}		100		mV
Junction Temperature in Constant Temperature Mode	T _{LIM}			120		°C

■ TYPICAL APPLICATION CIRCUITS

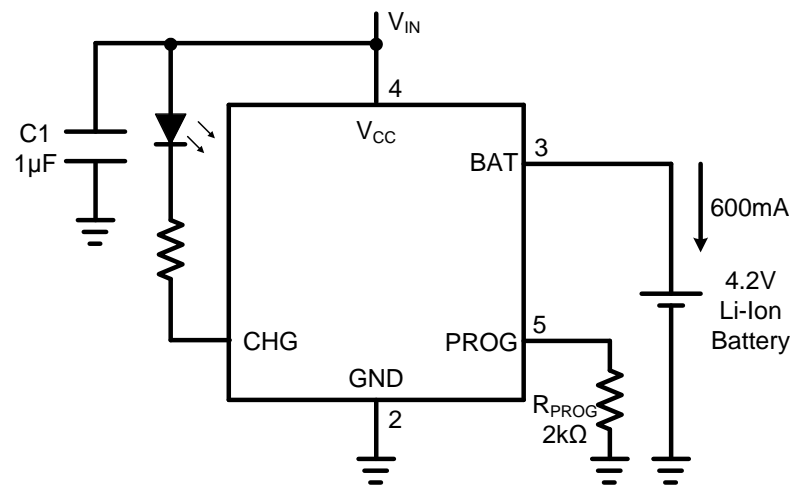
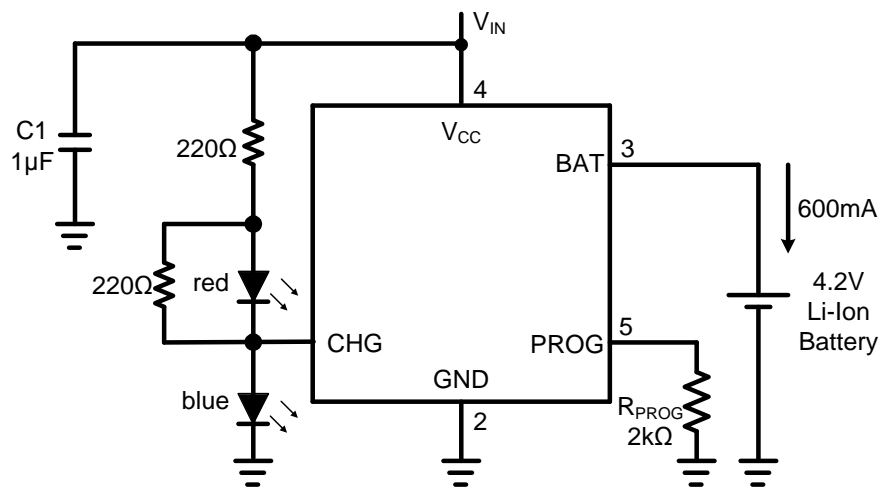

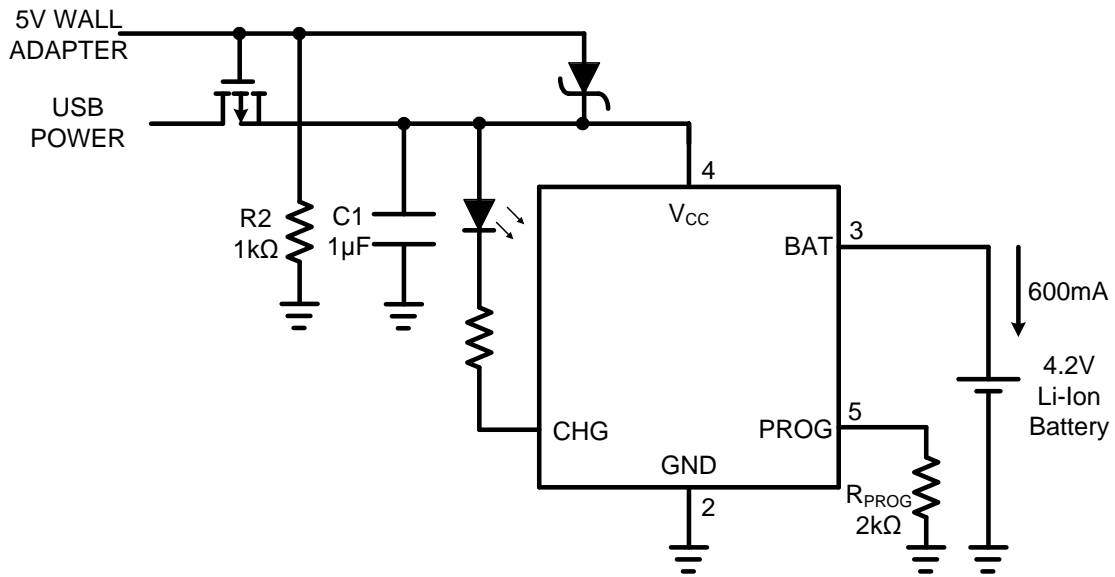

Figure1 Basic Application Circuit

■ OPERATION

The CE3150 is a standalone linear Li-ion battery charger with thermal regulation. It can deliver up to 800mA of charge current (using a good thermal PCB layout) with a final float voltage accuracy of ±1.2%.

No blocking diode or external current sense resistor is required. A charge cycle begins when the voltage at the VCC pin rises above the UVLO threshold level and a 1% program resistor is connected from the PROG pin to ground. If the BAT pin is less than 2.9V, the charger enters trickle charge mode. In this mode, the CE3150 supplies approximately 1/10 the programmed charge current to bring the battery voltage up to a safe level for full current charging. When the BAT pin voltage rises above 2.9V, the charger enters

constant-current mode, where the programmed charge current is supplied to the battery. When the BAT pin approaches the final float voltage (4.2V), the CE3150 enters constant-voltage mode and the charge current begins to decrease. When the charge current drops to 1/10 of the programmed value, the charge cycle ends.

After a charge cycle is complete and charging operation is terminated, the CE3150 keeps monitoring the BAT voltage. If the battery voltage drops below 4.05V, a recharge cycle will begin. To manually restart the charge cycle, the input voltage must be removed and reapplied, or the charger must be shut down and restarted by momentarily floating the PROG pin.

■ APPLICATION INFORMATION

PROGRAMMING CHARGE CURRENT

The charge current is programmed using a single resistor from the PROG pin to ground. The battery charge current is 1200 times the current

out of the PROG pin. The program resistor and the charge current are calculated using the following equations:

$$R_{PROG} = \frac{1200V}{I_{CHG}} \qquad I_{CHG} = \frac{1200V}{R_{PROG}}$$

STABILITY CONSIDERATIONS

The constant-voltage mode feedback loop is stable without an output capacitor provided a battery is connected to the charger output. With no battery present, an output capacitor is recommended to reduce ripple voltage. When using high value, low ESR ceramic capacitors, it is recommended to add a 1W resistor in series with the capacitor. No series resistor is needed if tantalum capacitors are used.

In constant-current mode, the PROG pin is in the feedback loop, not the battery. The constant-current mode stability is affected by the impedance at the PROG pin. With no additional capacitance on the PROG pin, the charger is stable with program resistor values as high as 20k. However, additional capacitance on this node reduces the maximum allowed program resistor. The pole frequency at the PROG pin should be kept above 100kHz. Therefore, if the PROG pin is loaded with a capacitance, C_{PROG} , the following equation can be used to calculate the maximum resistance value for R_{PROG} :

$$R_{\text{PROG}} \leq \frac{1}{2\pi \times 10^5 \times C_{\text{PROG}}}$$

Average, rather than instantaneous, charge current may be of interest to the user. For example, if a switching power supply operating in low current mode is connected in parallel with the battery, the average current being pulled out of the BAT pin is typically of more interest than the instantaneous current pulses. In such a case, a simple RC filter can be used on the PROG pin to measure the average battery current. A 10k resistor has been added between the PROG pin and the filter capacitor to ensure stability.

CHARGE STATUS INDICATOR

The charge status output has three different states: strong pull-down (~10mA), weak pull-down (~20 μ A) and high impedance. The strong pull-down state indicates that the CE3150 is in a charge cycle. Once the charge cycle has terminated, the pin state is determined by under voltage lockout conditions. A weak pull-down indicates that VCC meets the UVLO conditions and the CE3150 is ready to charge. High impedance indicates that the CE3150 is in under voltage lockout mode: either VCC is within 100mV of the BAT pin voltage or insufficient voltage is applied to the VCC pin. A microprocessor can be used to distinguish between these three states.

THERMAL LIMITING

An internal thermal feedback loop reduces the programmed charge current if the die temperature attempts to rise above a preset value of approximately 120°C. This feature protects the CE3150 from excessive temperature and allows the user to push the limits of the power handling capability of a given circuit board without risk of damaging the CE3150.

The conditions that cause the CE3150 to reduce charge current through thermal feedback can be approximated by considering the power dissipated in the IC. Nearly all of this power dissipation is generated by the internal MOSFET—this is calculated to be approximately:

$$P_D = (V_{\text{CC}} - V_{\text{BAT}}) \cdot I_{\text{BAT}}$$

where P_D is the power dissipated, V_{CC} is the input supply voltage, V_{BAT} is the battery voltage and I_{BAT} is the charge current. The approximate ambient temperature at which the thermal feedback begins to protect the IC is:

$$T_A = 120^\circ\text{C} - P_D \theta_{\text{JA}}$$

$$T_A = 120^\circ\text{C} - (V_{\text{CC}} - V_{\text{BAT}}) \cdot I_{\text{BAT}} \cdot \theta_{\text{JA}}$$

Reducing the voltage drop across the internal MOSFET can significantly decrease the power dissipation in the IC. This has the effect of increasing the current delivered to the battery during thermal regulation. One method is by dissipating some of the power through an external component, such as a resistor or diode. By dropping voltage across a resistor in series with a 5V wall adapter, the on-chip power dissipation can be decreased, thus increasing the thermally regulated charge current.

UNDER VOLTAGE LOCKOUT (UVLO)

An internal under voltage lockout circuit monitors the input voltage and keeps the charger in shutdown mode until VCC rises above the under voltage lockout threshold. The UVLO circuit has a built-in hysteresis of 100mV. Furthermore, to protect against reverse current in the power MOSFET, the UVLO circuit keeps the charger in

shutdown mode if VCC falls to within 30mV of the battery voltage. If the UVLO comparator is tripped, the charger will not come out of shutdown mode until VCC rises 100mV above the battery voltage.

MANUAL SHUTDOWN

At any point in the charge cycle, the CE3150 can be put into shutdown mode by removing R_{PROG} thus floating the PROG pin. This reduces the battery drain current to less than 2μA and the supply current to less than 50μA. A new charge cycle can be initiated by reconnecting the program resistor.

In manual shutdown, the CHG pin is in a weak pull-down state as long as VCC is high enough to exceed the UVLO conditions. The CHG pin is in a high impedance state if the CE3150 is in under voltage lockout mode: either VCC is within 100mV of the BAT pin voltage or insufficient voltage is applied to the VCC pin.

■ PACKAGING INFORMATION

● SOT-23-5L Package Outline Dimensions

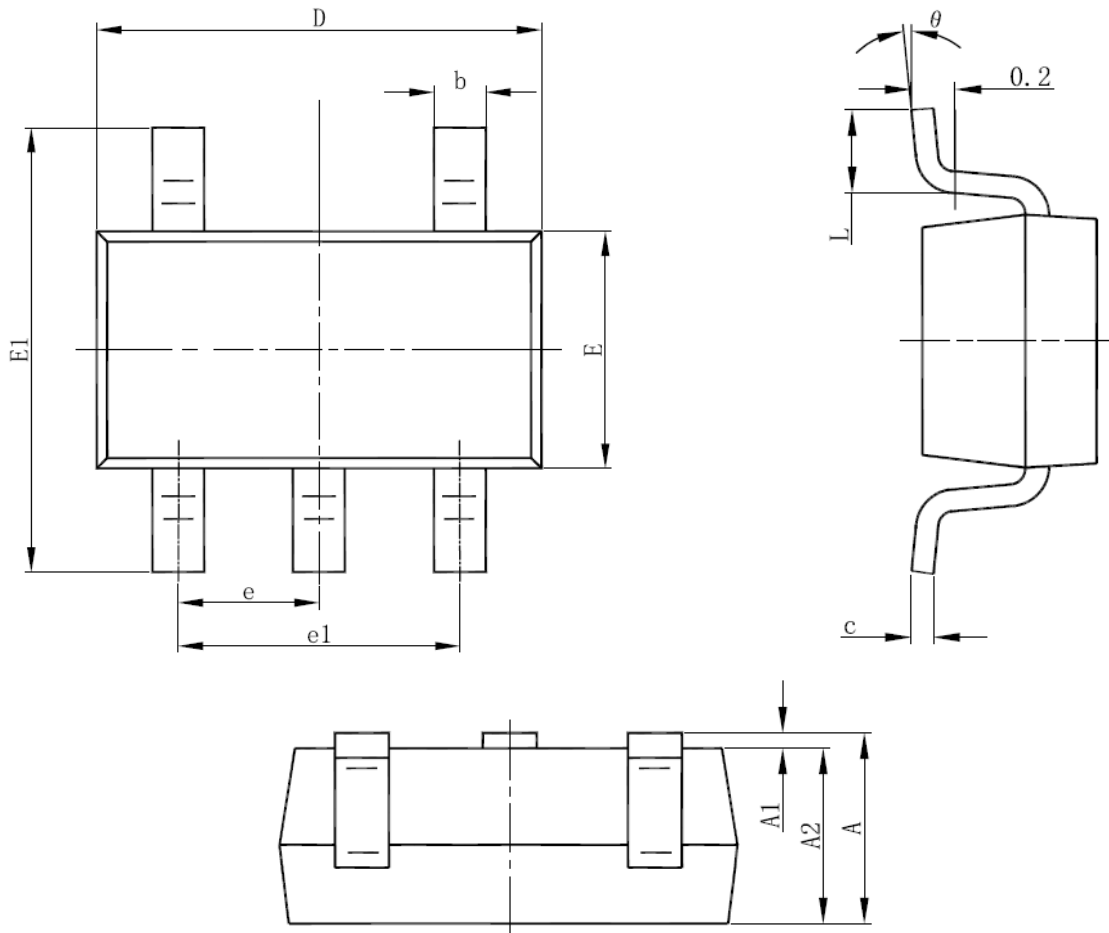

Symbol	Dimensions In Millimeters		Dimensions In Inches	
	Min	Max	Min	Max
A	1.050	1.250	0.041	0.049
A1	0.000	0.100	0.000	0.004
A2	1.050	1.150	0.041	0.045
b	0.300	0.500	0.012	0.020
c	0.100	0.200	0.004	0.008
D	2.820	3.020	0.111	0.119
E	1.500	1.700	0.059	0.067
E1	2.650	2.950	0.104	0.116
e	0.950(BSC)		0.037(BSC)	
e1	1.800	2.000	0.071	0.079
L	0.300	0.600	0.012	0.024
θ	0°	8°	0°	8°

© Nanjing Chipower Electronics Inc.

Chipower cannot assume responsibility for use of any circuitry other than circuitry entirely embodied in a Chipower product. No circuit patent license, copyrights or other intellectual property rights are implied. Chipower reserves the right to make changes to their products or specifications without notice. Customers are advised to obtain the latest version of relevant information to verify, before placing orders, that information being relied on is current and complete.